

DC300

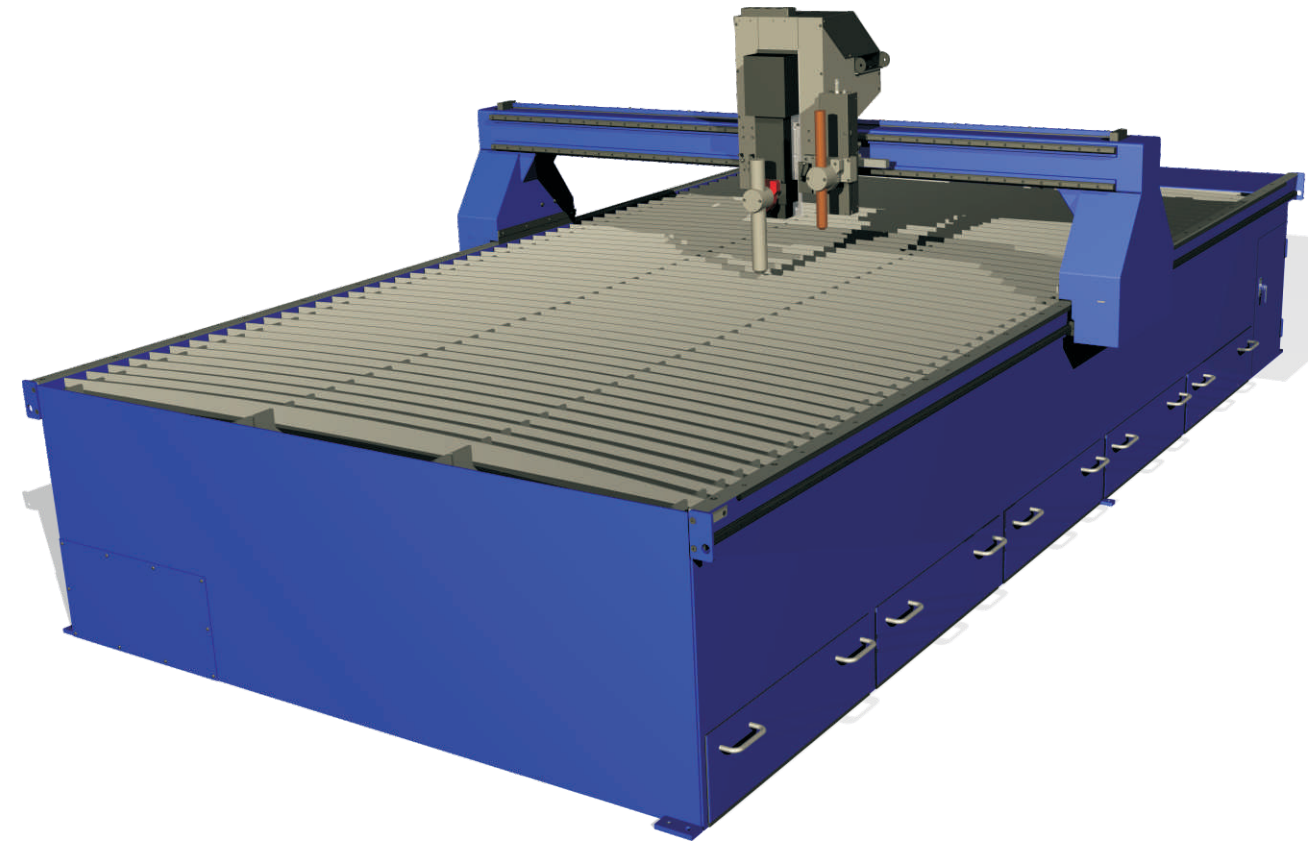

Cutting area	5 x 10	6 x 12	8 x 20
Table width	93" (2362mm)	105" (2667 mm)	129"(3277mm)
Table Length	184" (4674mm)	208" (5284mm)	304" (7722mm)
Housing	Mono frame. Zoned down draft table. 2 x duct connections.		
Bridge	6" x 6" in steel. Linear rail bearing		
Height Control	PHC from Hypertherm, option: THC		
Controller	Hypertherm Edge Ti, option: Edge Pro		
CNC Software	Phoenix from Hypertherm		
Controller Power Supply	115 VAC, 1ph, 60 Hz		
Tool available	Maximum 3		
Speed	Cutting: up to 800 ipm, Travel: 1000 ipm		
Plasma available	All Hypertherm product lines		
Pump Power Supply	From 200 to 600 vac, 3 Ph. 50/60 Hz, CSA		
Option	Oxyfuel torch, Pneumatic scriber, Laser pointer		
Software optional	Pronest 10		

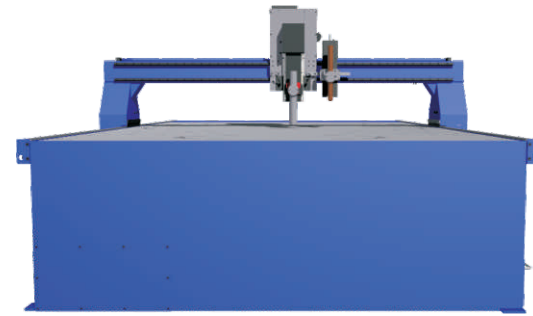
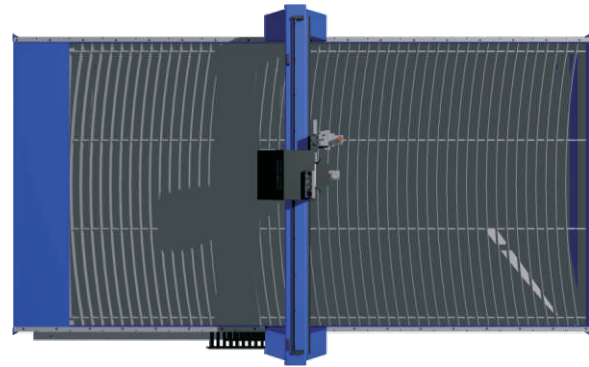

PLASMA

OXYFUEL

WATERJET

LASER

Distributor:



225, Boul. Bona-Dussault
 Saint-Marc-des-Carières, Qc
 Canada G0A 4B0
 Ph: 418-268-4020
 Fax: 418-268-4021
 info@machitech.ca

This machine is perfect for the fabricating shop who needs accuracy, efficiency and highly productive.



Edge Ti

The EDGE Ti is a fully integrated CNC. Boasting a SAW (surface acoustic wave) touchscreen, single station operator's console, and built-in servo amplifiers, the EDGE Ti is designed to provide easy installation and consistent performance.

HPR

HyPerformance Plasma delivers HyDefinition® cut quality with greater consistency, faster cut speeds, longer consumable life and half the operating cost of competing technologies. With over ten thousand systems in use worldwide, it is clear that HyPerformance Plasma is the system of choice for customers that demand performance they can count on.

Pneumatic scriber

The best tool for marking, writing, bend line, hole mark... Build only with industrial components, our scriber is maintenance free and simple of operation

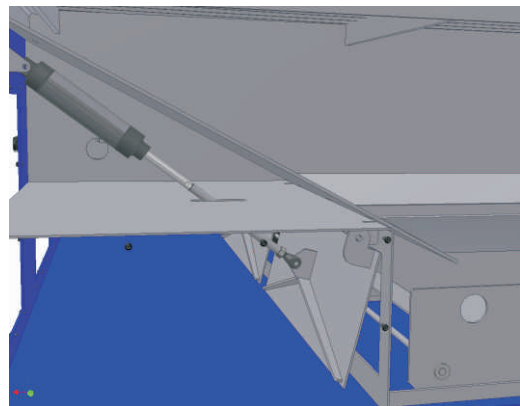

Zoned down draft

The controller drives the damper corresponding to the bridge's position. This reduces the blower size and increase the draft efficiency. Each damper is activated by a pneumatic cylinder.

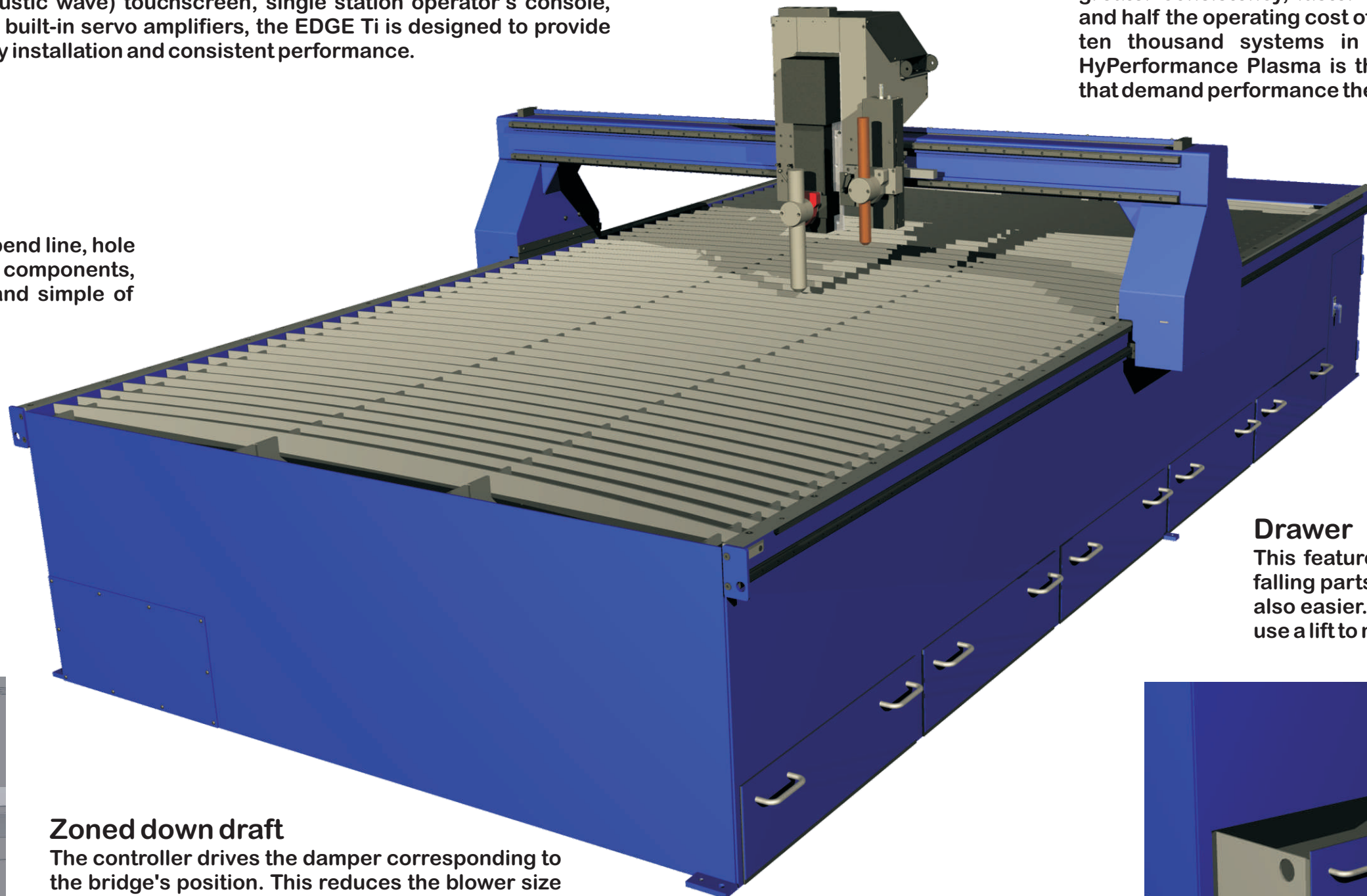

Drawer

This feature gives you an easy access to the falling parts. Remove the scrap and the dust is also easier. The drawer has wheels or you can use a lift to move it.

